

 **Therm-Omega-Tech, Inc.**

***Locomotive Freeze  
Protection***



**The Most Advanced, Reliable and Compact Self Contained  
Valves Available for Temperature Control, Freeze Protection,  
Steam Tracing and Conservation of Energy**

**[www.ThermOmegaTech.com](http://www.ThermOmegaTech.com)**



# Locomotive Freeze Protection

## Fixed Volume Systems

This system is defined by its name: fixed volume. It has a definite volume of water in it which does not fluctuate and may be separately pressurized or operate under its own head pressure. The cooling systems in use on US and Canadian diesel locomotives are fixed volume systems, using an all-water cooling because it is not economical to use an antifreeze solution. As a result, should the engine be shut down for any reason during sub-freezing weather, there is a danger of freeze damage that could reach thousands of dollars in parts and labor. The engine cooling system is a closed loop, with a pump circulating the water from the engine where it absorbs heat, to the radiators where the heat is dissipated, and back to the engine.

**Therm-Omega-Tech's GURU™ Plugs** were developed expressly for fixed volume applications. When the engine is running, the warm water passing by the valve keeps the valve shut. After the engine shuts down, the whole system cools. Before the series of small tubes in the system can freeze, the water sensing qualities of the **GURU™ Plug** cause it to snap open. This will drain the whole system rapidly before any freeze can occur. This snap acting valve must be used because there is no source of warmer water to purge the system, as there is in the re-supply system. By installing the valve at the lowest point in the system, complete drainage is ensured.

## A Brief Case History

Several major railroads located in the northeast and midwestern U.S. have installed **GURU™ Plugs** on nearly all their locomotives. This is a part of the country where freezing is a fact of life for at least five months of the year, if not longer. One of their managers informed us that one of their locomotives was in shut-down mode and unintentionally left for too long. He was pleasantly surprised to find out that the **GURU™** drained the system as the temperature of the cooling water in the piping dropped to near freezing. This eliminates any possibility of a damaging freeze within the system. After refilling the system and re-inserting the warmed cartridge into the **GURU™ Plug**, the locomotive was back in operation within hours, quickly and efficiently. Had the "dump" not occurred, thousands of dollars worth of damage would have been done, taking the locomotive out of operation for a long period of repair. In the past, the only sure way of avoiding freezes without such system protection was to leave the engines running constantly, resulting in a tremendous waste of fuel and energy and contributing unnecessarily to air pollution.

## GURU™ DL 2.1 Series

DL Type S



DL Type T



DL Type FL



DL Type CH

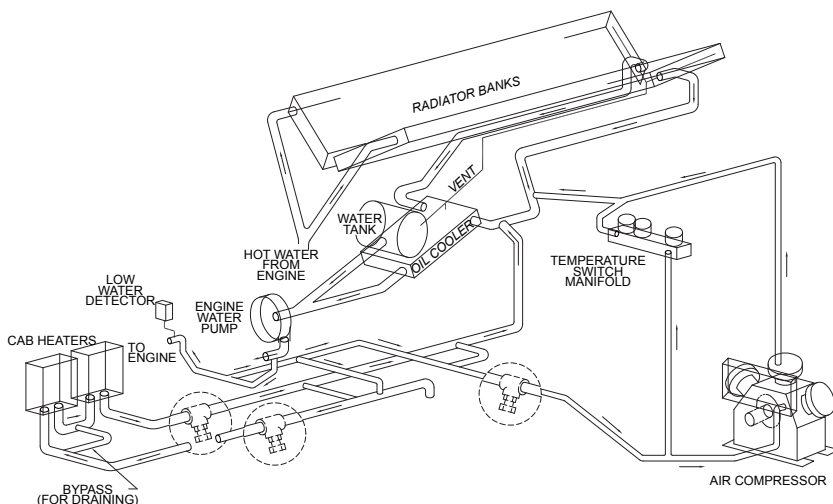

## Advantages

- Will not trip or dump while locomotive is running
- Easy installation
- Completely mechanical - No electrical or air connections
- Not affected by air flow or air temperature surrounding valve
- Rapid draining
- Easy system refill
- Models available to convert existing freeze protection
- Easily tested in field
- Slotted actuator feature prevents dumps when refilling cooling system with cold water.
- Unit automatically rearms after filling and reheating

# Locomotive Freeze Protection

## Magnum GURU™ Series

The **Magnum GURU™ Plug** is a higher discharge capacity version of the standard GURU™ Plug. The Magnum GURU™ Plug is a self-operating thermostatic drain valve that responds to engine coolant temperature and will pop open and drain when coolant reaches the setpoint (40°F). This provides almost a full 1.2 inch bore to rapidly drain a locomotive before freeze damage can occur.

Resetting and rearming the Magnum GURU™ Plug is easily accomplished by simply reheating the cartridge and utilizing the slotted actuator feature (AKA “penny pincher”). This feature prevents the GURU™ Plug from triggering open again while refilling the cooling system with cold water.



Magnum S



Magnum T



Magnum FL

## Advantages

- Drains twice as fast as the standard GURU™ Plug
- Will not trip or dump while locomotive is running
- Straight SAE threads and O-ring seals
- Easy installation, field testing & maintenance and system refill
- Completely mechanical - No electrical or air connections
- Not affected by air flow or air temperature surrounding valve - releases only when cooling water reaches setpoint
- Hex body/cartridge assembly on Magnum types T and FL can be maintained or replaced without draining cooling system
- Models available to convert existing freeze protection
- Slotted actuator feature prevents accidental dumps when refilling cooling system with cold water.
- Unit automatically rearms after filling and reheating

## Design Features

- Actuator sensing surface is the only wetted part
- Design excludes cooling water chemicals and other debris from moving parts
- Long service life: All moving parts are stainless steel
- Plug has SAE threads and O-ring seals for easy field maintenance and testing
- Available in 1-1/4" NPT tee and flanged tee body styles
- Paint mask minimizes accidental paint-ins
- Knob on cartridge for easy installation and removal even in awkward locations

## Passenger Car Freeze Protection



**IC/FP (Freeze Protection)** valves are ideal for the protection of piping, safety showers, condensate systems, fire lines, spray nozzles, or as backup protection on traced systems, where an unrestricted flow is required under normal operating conditions. Its sensitivity to water temperature makes this valve ideal for applications where water conservation or wastewater disposal are a prime concern. The IC/FP is being used in conjunction with the GURU™ Plug to provide localized freeze protection in sensitive areas that show some tendency to freeze even when the GURU™ Plug is functioning properly.



**HAT/FP (Freeze Protection)** valves are ideal for protection of piping, valves, fittings, pumps, condensate systems, safety showers, fire lines, spray nozzles, freeze sensitive equipment, or as backup protection on traced systems/equipment.

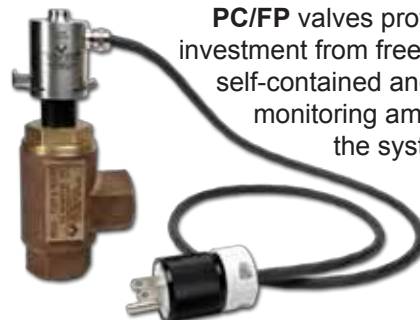

**PC/FP** valves protect your passenger car investment from freeze damage. This valve is self-contained and operates automatically monitoring ambient temperature purging the system before freeze damage can occur. Since the valve is completely mechanical, no electrical or air connections are required if used without heater assembly.

Therm-Omega-Tech, Inc. is an Industry Expert and Leading Manufacturer of Custom Thermostatic Valves, Actuators and Controls serving domestic and international markets for over 25 years.



For sales and technical assistance:

Call: 1-877-379-8258 or 215-674-9992

Fax: 215-674-8594

E-mail [valves@ThermOmegaTech.com](mailto:valves@ThermOmegaTech.com)

Web [www.ThermOmegaTech.com](http://www.ThermOmegaTech.com)

*Look for us on Facebook, Twitter and YouTube!*



**Your local representative**

