

Stay Out of Hot Water with DTV

ThermOmegaTech®'s Drain Tempering Valve Keeps Drain Water Up to Code

Drain water from commercial equipment exceeding 140°F can be costly - leading to failed inspections, fines, business interruptions, or injury and damage to personnel and equipment. ThermOmegaTech®'s rugged, clog-resistant Drain Tempering Valve (DTV) is completely self-operating in any orientation, requires no power or signal, and is easy to install. Simply install into the drain line and the water supply connects to the inlet.

When the drain temperature rises above the setpoint, the valve opens to let cold water in and mix proportionately with the high temperature effluent allowing the drain temperature to decrease. Once water temperature falls, it automatically shuts off the cold water flow. This results in a minimum amount of wasted water while complying with international plumbing codes.

Available in 1/2", 3/4", and 1" sizes, brass or stainless steel, DTV provides a convenient, economical, and easy to use method of tempering hot effluent flows. Since the DTV is open only when the effluent exceeds the specified setpoint temperature, it also conserves water by automatically turning off cold water when not needed.



For more information on ThermOmegaTech®'s DTV, visit www.ThermOmegaTech.com/DTV

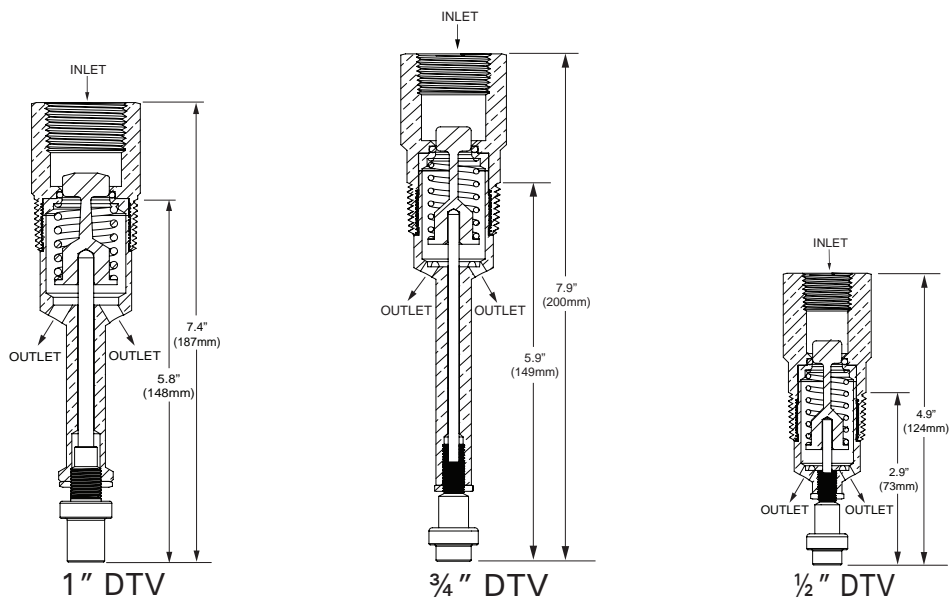

SPECIFICATIONS

Maximum Inlet Pressure.....	125 PSIG/ 8.6 BAR
Maximum Temperature.....	250°F/ 121°C
Weight	Flow Coefficient
1/2" 1.1Lbs/0.5Kg	1/2" 2.0
3/4" 1.2Lbs/0.5Kg	3/4" 2.0
1" 1.5Lbs/0.7Kg	1" 4.0
Size (NPT)	
Water Drain	
Inlet Connection	
1/2" 1"	
3/4" 1"	
1" 1-1/4"	

SAMPLE CALCULATION

How much effluent can be tempered with a 1" DTV valve?

1) Flow capacity through cold water port of 1" DTV with Cv = 4.0:
 $CW\text{ gpm} = C_v \times \sqrt{\text{pressure drop}}$
 Assume 50 psig cold water pressure, drain pressure = 0psig
 $CW\text{ gpm} = 4 \times \sqrt{50} = 28.3\text{ gpm}$
 Assume for this example:
 cold water temp = 60°F (CT)
 hot effluent temp = 212°F (HT)
 max. allowable drain temp = 140°F (MT)

2) Maximum effluent flow (gpm) that can be tempered:
 $CW \times (MT-CT)/(HT-MT)$
 $MT-CT=80$
 $HT-MT=72$
 Maximum effluent flow rate = $28.3 \times 80/72 = 31.4\text{ gpm}$

BENEFITS

- Rugged, clog resistant valve design
- Easily installed using standard pipe fittings and tools
- Operates in any orientation
- Minimizes water waste
- Modulates to conserve cooling water
- Effluent tempering capacity limited only by cold water flow rate through DTV

ORDERING INFORMATION

325-000000-XXX	1/2" DTV
325-100000-XXX	1/2" DTV Stainless Steel
326-000000-XXX	3/4" DTV
326-100000-XXX	3/4" DTV Stainless Steel
327-000000-XXX	1" DTV
327-100000-XXX	1" DTV Stainless Steel

TYPICAL INSTALLATIONS

