

## INSTALLATION INSTRUCTIONS GURU® CHS

**Before installing GURU® Plug, remove nose seal protector from cartridge**

1. Select locations for **GURU PLUGS**: These should be at the lowest points in the system to be freeze protected and should be accessible for future re-arming.
2. Install the **GURU PLUG** with its cartridge down or at a 45° angle (as shown) for best accessibility. (Make sure lanyard is placed over paint mask and not between paint mask and cartridge tip. Paint mask must be cupped toward cartridge tip.) **Do not remove paint mask (cover) on cartridge. Do not cut lanyard!**
3. **GURU PLUG** must be installed with a 2 -inch minimum operating clearance to allow cartridge to pop out.
4. Cartridge can be removed by pushing in and twisting counter-clockwise (no tools required) and re-installed by pushing in and twisting clockwise.
5. Under freezing conditions, cartridge may be re-installed after reheating.

**IMPORTANT:** To operate properly in extreme conditions, the GURU assembly must be dry. If the actuator nose seal leaks or drips, replace hex nut and cartridge immediately.

**CAUTION:** When re-arming GURU always melt any ice formations from cartridge and inside of hex body prior to installing GURU PLUG Cartridge to prevent seal damage.

**NOTE:** Cartridge and inside of hex body must be dry before assembly.

6. Preferred method of testing: GURU Plug must be removed from cooling system for proper testing. Horizontally place the assembly on a flat surface. Using a can of freeze spray (available through most home-building supply stores or specialty suppliers) intermittently spray the actuator nose to keep a layer of frost on the metal surface. Cartridge should pop within one minute. If not, replace entire unit. Warm the cartridge before reinstalling.

**To remove GURU PLUG CARTRIDGE for service or warming\*:**

Push cartridge in and twist to the left (counter-clockwise) until it stops. Cartridge will pop out. Remove loop of lanyard cable from GURU Cartridge.

**To reinstall GURU PLUG CARTRIDGE\*:**

Make sure GURU Cartridge is warmed to 55°F or higher. Replace loop of lanyard in groove of cartridge. Make sure lanyard is placed over paint mask and not between paint mask and cartridge tip. Paint mask must be cupped toward cartridge tip. Push cartridge in and turn to the right until locked. Do not remove paint mask (cover) on cartridge.

**\*Prior to filling system with cold water, warm cartridge and place the GURU Flag and Clip tool (shown at right: part number 04-052) in the slotted actuator to prevent cartridge from firing. This will provide a visual indication that a GURU cartridge is disabled. Do not use if you do not plan to immediately operate locomotive.**

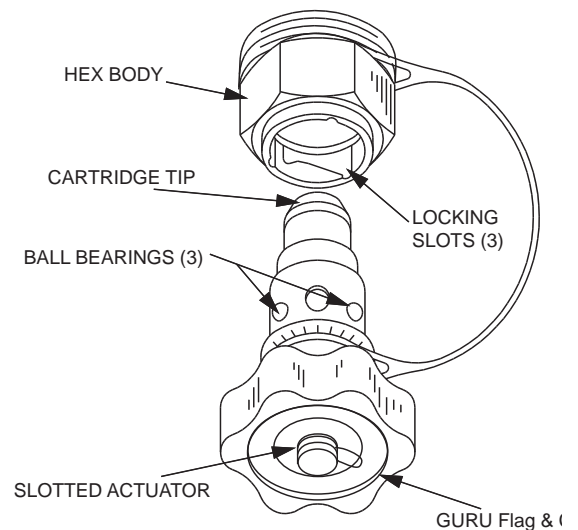

# GURU® CHS

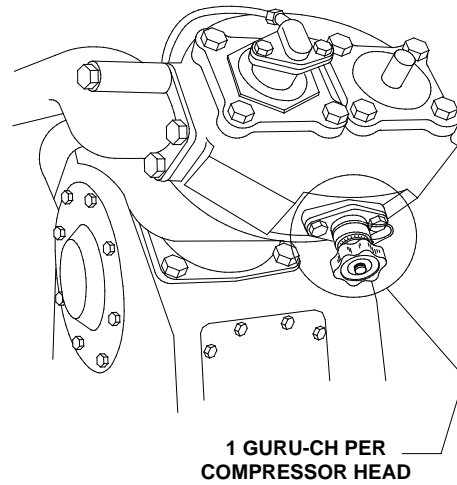
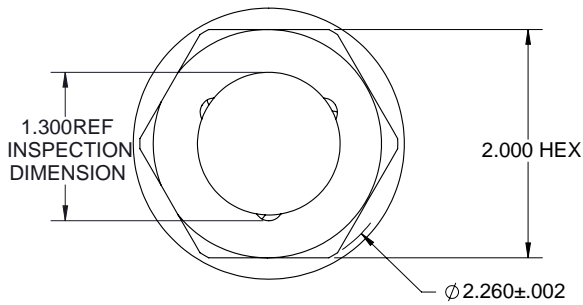
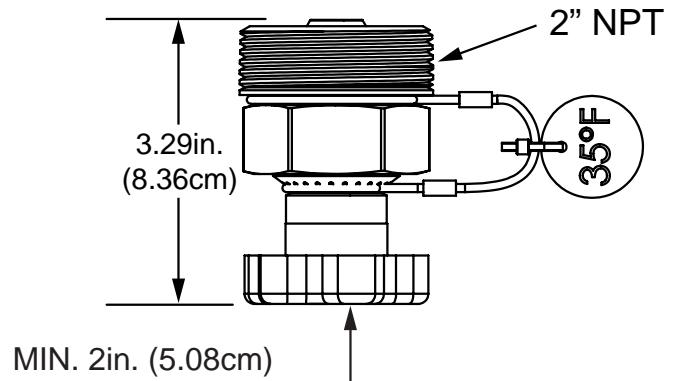
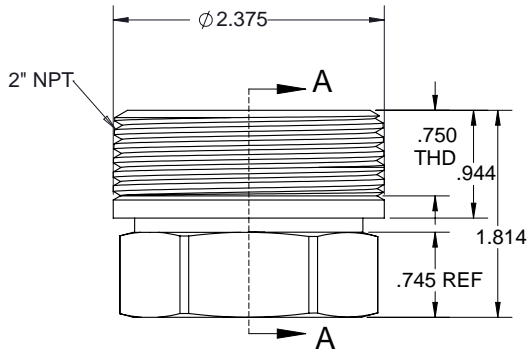

**Note:** Max value rotation angle is 45°

## YEARLY COLOR CODES (CHANGES JANUARY 1)

2017 YELLOW

2018 WHITE

2019 RED

2020 SILVER

2021 GREEN

2022 YELLOW

SERIES REPEATS