

GURU® DL 2.1

LOCOMOTIVE FREEZE PROTECTION



BENEFITS

- Will not trip or dump while locomotive is running
- Fully automatic - it never forgets to activate freeze protection
- Completely mechanical - No electrical or air connections
- Not affected by air flow or air temperature surrounding valve - releases only when cooling water reaches set point
- Rapid draining
- Easy system refill
- Models available to convert existing freeze protection
- Easily tested in field
- Slotted actuator feature prevents nuisance dumps when refilling cooling system with cold water
- Unit automatically rearms after filling and reheating
- Optional domed anti-tamper cap eliminates ability to tamper with the valve resetting stem



DESIGN FEATURES

- Actuator sensing surface is the only wetted part
- Long service life: All moving parts are stainless steel
- Design excludes cooling water chemicals and other debris from moving parts
- Easy maintenance
- Several body styles available for various applications: 1-1/4 NPT, tee, and flanged tee.
- Paint mask minimizes accidental paint-ins
- Knob on cartridge for easy installation and removal even in awkward locations
- Choice of release temperatures: 35°F or 40°F
- Extra port for temperature bushing

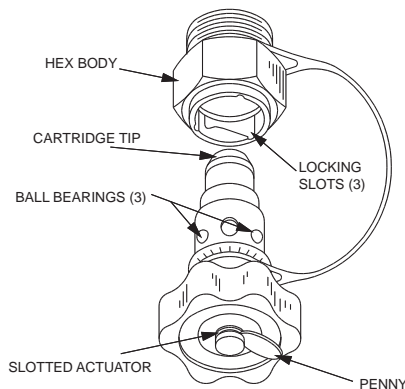

The GURU® DL 2.1 Plug is available in the models shown for new installations or to retrofit existing freeze protection systems by Ogontz, Prime, Salem, Graham-White, and Microphor.

OPERATION

The GURU® DL 2.1 is the most widely used and proven locomotive freeze protection valve in the world. It may be thought of as an automatic freeze-out plug with one important difference: The stainless steel GURU® Cartridge releases itself from its body at a pre-set water temperature (35°F or 40°F), rather than being forced out by the tremendous pressure of expanding ice. This provides almost a full one inch bore to rapidly drain the typical locomotive before damage can occur.

Resetting and rearming the GURU® Plug is easily accomplished by simply reheating the cartridge and utilizing our GURU® Flag and Clip tool with slotted actuator feature. This feature prevents the GURU® Plug from triggering open again while refilling the cooling system with cold water.

APPLICATIONS

- Locomotive engine and compressor set cooling systems
- Stand-by diesel heating circulators
- Back-up protection in event of shut-down
- Hot water cab heater lines
- On-board tanks and piping

GURU[®] DL 2.1

LOCOMOTIVE FREEZE PROTECTION



DL 2.1 TYPE S

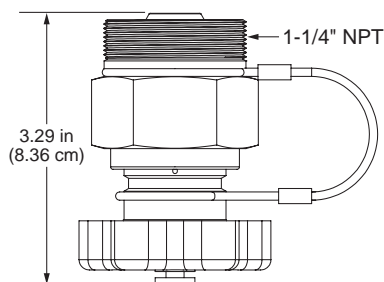

DL 2.1 TYPE T

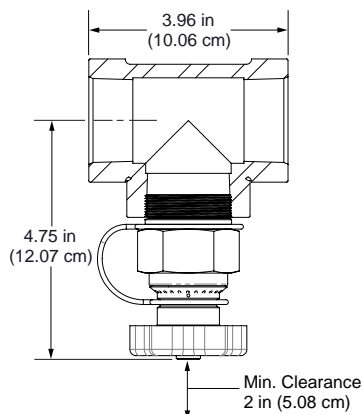

TYPE-S ANTI-TAMPER



DL 2.1 TYPE FL & FL/GX

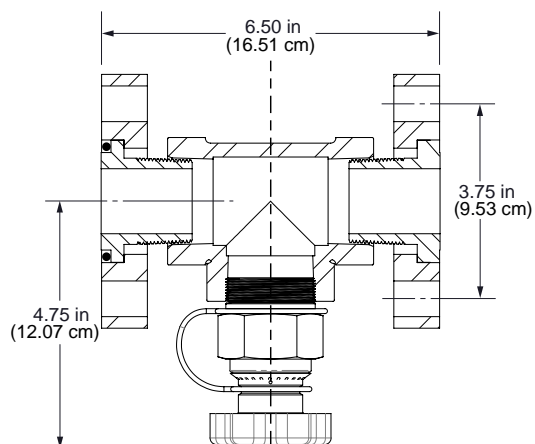

DL 2.1 TYPE CR/FL/P & CR/FLGX/P

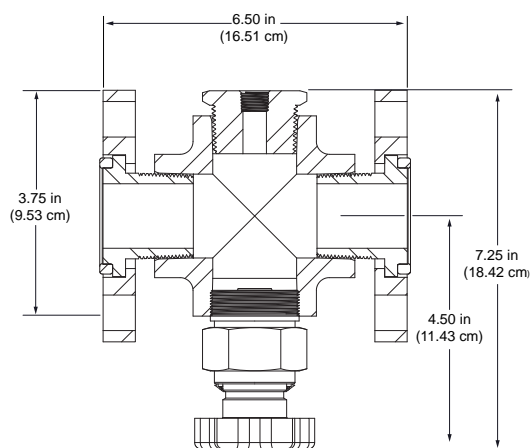

*Available with both flanges grooved (Type FL) or both flanges flat-faced (FL-GX).

ORDERING INFORMATION

PART NUMBER		DESCRIPTION	NOTES
35°F RELEASE	40°F RELEASE		
481-04-82-CART	481-04-81V-CART	DL 2.1 CARTRIDGE	REPLACEMENT GURU [®] DL CARTRIDGE
487-04-88	487-04-87	DL 2.1 TYPE-S	
482-04-88	482-04-82	DL 2.1 TYPE-T	
483-04-88	483-04-83	DL 2.1 TYPE-FL	GROOVED FLANGE QUAD SEAL
483-04-88-GX	483-04-83-GX-V	DL 2.1 TYPE-FLGX	FLAT FACED FLANGES
475-009100-035		DL 2.1 TYPE CR/FL/P	CROSS VALVE w/ PLUG & GROOVED FLANGE QUAD SEAL
475-008100-035		DL 2.1 TYPE CR/FLGX/P	CROSS VALVE w/ PLUG & FLAT FACED FLANGES
475-001110-035		TYPE-S 35°F: ANTI-TAMPER	

FOR WATER COOLED AIR COMPRESSOR FREEZE PROTECTION, SEE GURU[®] CH & CHS PRODUCT SHEET.

The suitability of the valve for the intended application is the responsibility of the end user. GURU[®] DL 2.1 valves are covered by a 1-year warranty.



ThermOmegaTech[®], Inc.
353 Ivyland Road
Warminster, PA 18974

1-877-379-8258
www.ThermOmegaTech.com



GURUDL2.1
Rev: 7/10/18

Because of continuous improvements, ThermOmegaTech[®], Inc. reserves the right to change the design and specifications without notice