

Embrace the Technology

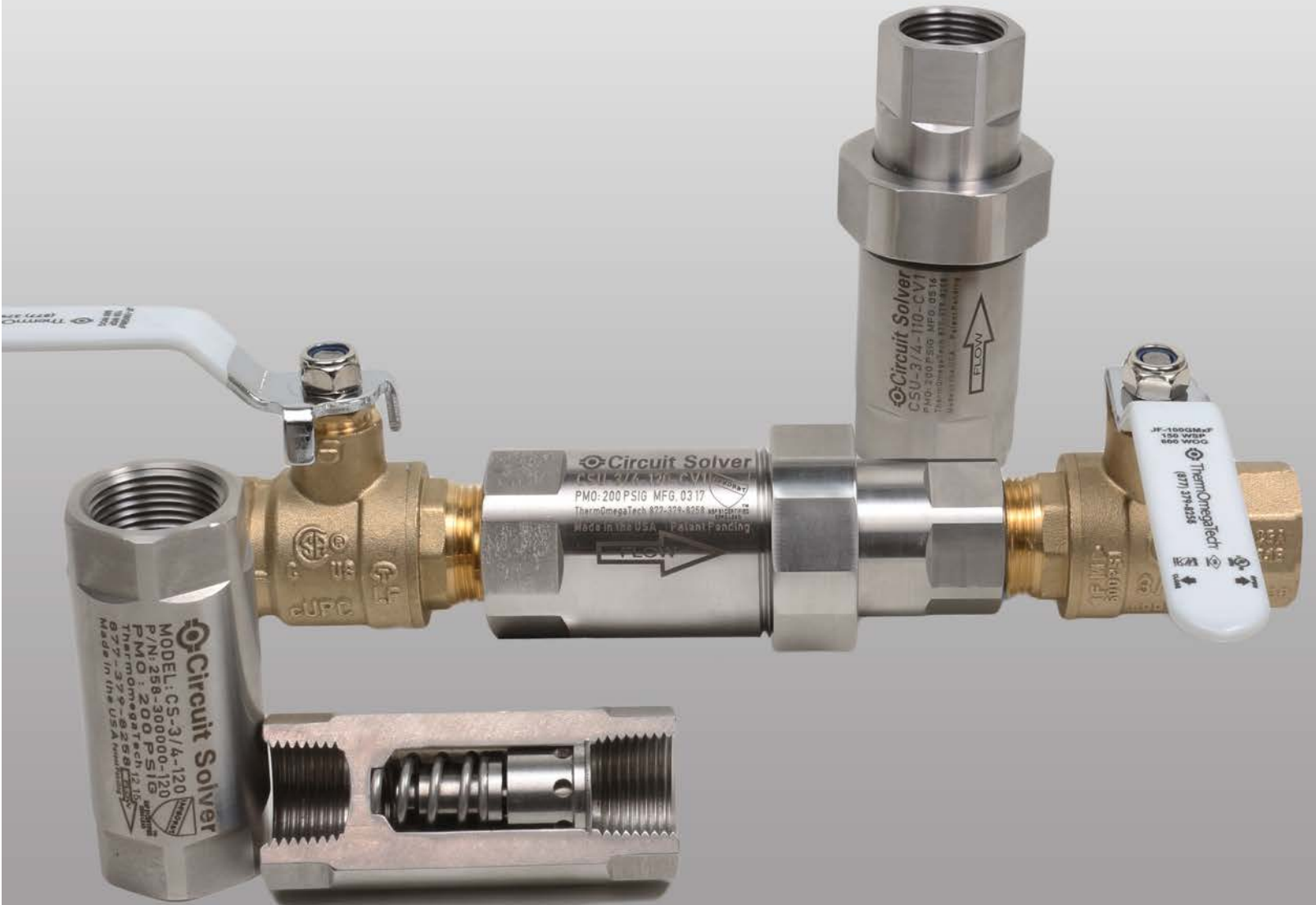

# CircuitSolver®

A ThermOmegaTech® product



THERMOSTATIC BALANCING VALVE  
FOR DOMESTIC HOT WATER SYSTEMS



All CircuitSolver® Valves and  
Components are NSF/ANSI 61  
Certified

CircuitSolver.com  
1-877-379-8258

The CircuitSolver<sup>®</sup> is a thermostatic self-actuating balancing valve that continuously adjusts the flow through each branch of a domestic hot water recirculation system to maintain the specified temperature at the ends of the branches. This simple in-line valve completely eliminates the need for time-consuming and expensive manual balancing labor and equipment. It also minimizes flow through the system by only allowing small amounts of water to pass through once the set point is reached, which reduces system wear and allows for a smaller circulator that won't consume as much power.

Most importantly, by installing CircuitSolvers at the end of each hot water branch you are ensuring that hot water will be available where and when it is needed.

## Advantages of Installing CircuitSolver<sup>®</sup>

1

Eliminates costs of balancing and re-balancing the system.

2

More efficient balancing means reduced pump size.

3

Lower GPM through system increases component life.

## The Problem

Domestic hot water recirculation systems need to be balanced in order to ensure that hot water is always available throughout the building. This is complicated because water flows in the path of least resistance and in open systems like these that can change constantly.

## The Solution

Make the CircuitSolver<sup>®</sup> your balancing valve of choice. It's a direct replacement for other balancing valves so they get installed in the same location and use the same accessories (unions, ball valves, etc.).

## How It Works

The CircuitSolver<sup>®</sup> uses a thermal actuator to control the flow of water through a branch. It continually monitors and responds to the temperature in the line to direct the hot water where it's needed. When the water is below the set point the CircuitSolver<sup>®</sup> opens allowing water to flow through easily. When the water temperature reaches the set point the CircuitSolver<sup>®</sup> closes down to keep the hot water at the fixtures and forces the additional water on to the other branches maintaining a constantly balanced system.

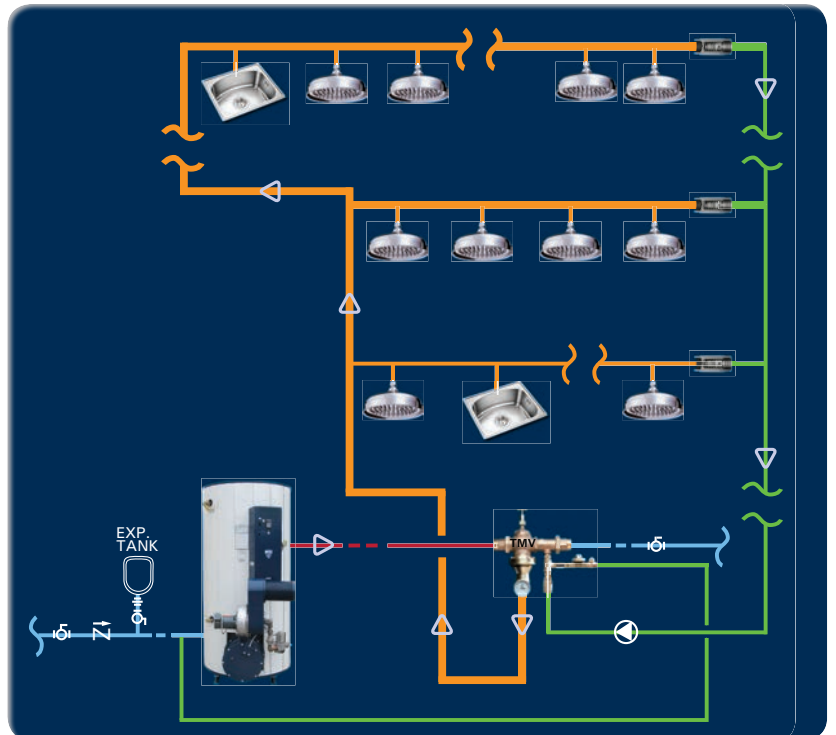

## Features

- Never fully closes, some water always passing through
- High thrust actuator keeps orifice free of debris
- Lead free for use in potable water systems
- All Stainless Steel, Corrosion Resistant Construction
- Long service life and 3 year warranty

With CircuitSolver<sup>®</sup> you get hot water where you need it at every turn of the tap automatically, reliably and economically.

### CircuitSolver® GPM and Cv

Valve Size	Model Number	GPM at 5 psi differential		C <sub>v</sub>		
		Open	Closed*	Open	Closed*	Design <sup>4</sup>
½"	CS-1/2-XXX	2.9	0.2	1.3	0.1	0.6
¾"	CS-3/4-XXX	4.0	0.2	1.8	0.1	0.85
1"	CS-1-XXX	7.4	0.2	3.3	0.1	1.57
1¼"	CS-1-1/4-XXX	11.4	0.3	5.1	0.15	2.48
1½"	CS-1-1/2-XXX	17.0	0.3	7.6	0.15	3.72
2"	CS-2-XXX	31.8	0.3	14.2	0.15	7.02

Flow rate calculation using Cv factor shown.

$$GPM = C_v \sqrt{\Delta P}$$

$$C_v = \sqrt{\frac{GPM}{\Delta P}}$$

$$\Delta P = \left[ \frac{GPM}{C_v} \right]^2$$

1. XXX = Desired close temperature
2. Open temperature = XXX-10°F
3. Valve position is linear with temperature. Example: For a 110°F desired return temperature, CircuitSolver® is approximately 60% open at a water temperature of 104°F
4. Use the Design Cv to calculate pressure loss across the CircuitSolver®. (Refer to the CircuitSolver® design guide.)

GPM = U.S. GPM  
 Δ P = pressure difference between inlet and outlet (psi)

\*CircuitSolver® valves never *fully* close. Built-in bypass leakage eliminates pump deadheading and improves upstream sensitivity.

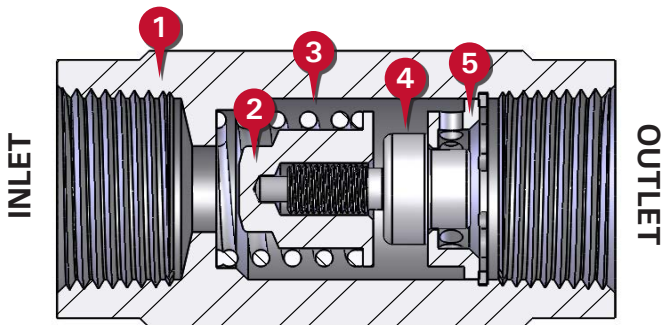

Item	Description	Material
1	Valve Body	303 SS
2	Valve Plug	303 SS
3	Spring	302 SS
4	Thermal Actuator	303 SS
5	Carrier	303 SS

 NSF/ANSI 61 Certified

Note: The valve plug is shown in the fully open position. As temperature rises, the thermal actuator moves it to the left towards the inlet port to limit flow to a trickle as temperature exceeds the set point.

Model Number	NPT	Diameter		Length		Weight		Maximum Operating Pressure		Maximum Temperature	
		IN.	MM	IN.	MM	LBS.	KG	PSIG	BAR	°F	°C
CS-1/2-XXX	½"	1.1	29	2.8	70	0.5	0.2	200	14	300	149
CS-3/4-XXX	¾"	1.4	35	3.1	80	0.8	0.4				
CS-1-XXX	1"	1.8	44	3.4	86	1.6	0.7				
CS-1-1/4-XXX	1¼"	2.1	54	4.6	117	2.8	1.3				
CS-1-1/2-XXX	1½"	2.4	60	4.6	117	3.5	1.6				
CS-2-XXX	2"	3.0	76	4.9	124	5.6	2.5				

#### Model Selection

XXX refers to the desired closing temperature. Use that temperature to complete the model number. For example, if you want 120°F desired return temperature and the CircuitSolver® is to be installed on a ¾" line, the model number would be CS-¾-120.

CircuitSolver® is fully open approximately 10°F below the closing temperature. Typical closing temperatures include: 100°F, 105°F, 110°F, 115°F, 120°F, 125°F, 130°F, 135°F, 140°F, and 150°F.

## CircuitSolver® Union (CSU)

This enhanced CircuitSolver® comes with a union and an optional check valve built into the body. It reduces the number of components to be installed and minimizes potential leak points. The stainless steel union features an integrated O-ring for a hand-tightened, leak-free seal.

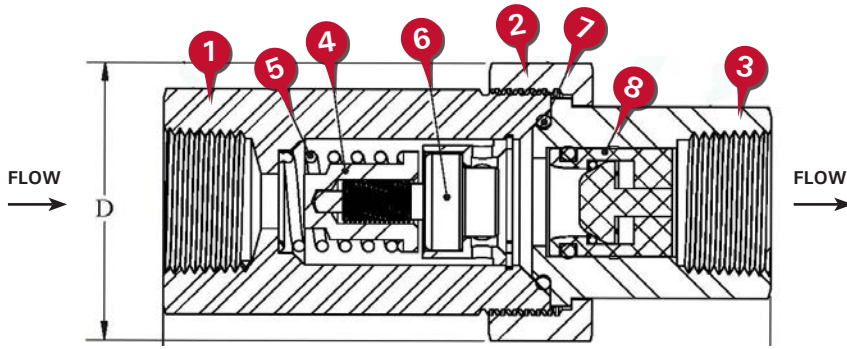

Item	Description
1	Body w/ Union Threads
2	Union Nut
3	Female Threaded Insert
4	Plug
5	Operating Spring
6	Actuator
7	O-ring
8	Check Valve



NSF/ANSI 61 Certified

Model Number	Check Valve	NPT	Diameter		Length		Weight		C <sub>v</sub>		Maximum Operating Pressure		Maximum Temperature	
			IN.	MM	IN.	MM	LBS.	KG	Open	Closed	PSIG	BAR	°F	°C
CSU-1/2-XXX		½"	1.8	46	3.7	94	1.2	0.5	1.3	0.1	200	14	250	121
CSU-1/2-XXX-CV1	Included													
CSU-3/4-XXX		¾"	2.0	51	4.3	110	1.9	0.9	1.8	0.1				
CSU-3/4-XXX-CV1	Included													
CSU-1-XXX		1"	2.5	64	4.7	120	3.1	1.4	3.3	0.1				
CSU-1-XXX-CV1	Included													

## CircuitSolver® Assembly (CSUA)

We have raised the bar even higher by adding isolation valves to either side of the CSU, making it the easiest and most efficient balancing valve to specify and install. Everything needed for a balanced system comes assembled and leak tested. The Male x Female isolation valves mean fewer potential leak points and a compact profile.

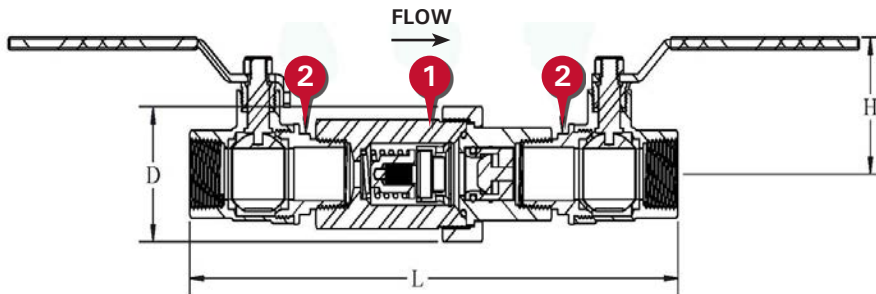

Item	Description
1	CircuitSolver® Thermostatic Balancing Valve w/ integrated union
2	Ball Valve, M x F, Lead Free

All components are NSF 61 Certified for use in domestic water systems

Model Number	Check Valve	NPT	Diameter		Length		Height		Weight		C <sub>v</sub>		Maximum Operating Pressure		Maximum Temperature	
			IN.	MM	IN.	MM	IN.	MM	LBS.	KG	Open	Closed	PSIG	BAR	°F	°C
CSUA-1/2-XXX		½"	1.8	46	7.7	196	1.8	46	2.5	1.1	1.3	0.1	200	14	250	121
CSUA-1/2-XXX-CV1	Included															
CSUA-3/4-XXX		¾"	2.0	51	8.9	226	2.0	51	3.4	1.5	1.8	0.1				
CSUA-3/4-XXX-CV1	Included															
CSUA-1-XXX		1"	2.5	64	10.5	267	2.3	59	5.4	2.5	3.3	0.1				
CSUA-1-XXX-CV1	Included															

### Model Selection

XXX refers to the desired closing temperature. Use that temperature to complete the model number. For example, if you want 120°F desired return temperature and the CircuitSolver® Union or Assembly is to be installed on a 3/4" line, the model number would be CSU-3/4-120 or CSUA-3/4-120. To add optional check valve insert -CV1 directly after the temperature designation in the model number.