



CircuitSolver®

A ThermOmegaTech® product

CircuitSolver® Union Assembly ProPress® Balancing For The Pros, By The Pros

Installed in seconds, Viega ProPress® ends make the CircuitSolver® thermostatic balancing valve now even easier to implement into domestic hot water systems. Viega Smart Connect® technology enables easy identification of unpressed connections, saving time, money, and callbacks.

CircuitSolver® Union Assembly ProPress (CSUA-PP)

For seamless installation, operation, and maintenance, the CircuitSolver® Union Assembly ProPress combines the CircuitSolver® Union Assembly's efficient and reliable domestic hot water balancing technology with Viega ProPress® ends.

To ensure complete peace of mind, each and every unit is fully assembled and leak tested before leaving our facility. The CircuitSolver® technology you rely on to automatically and continuously balance your domestic hot water system has never been easier! An integrated strainer is available for water systems with particulate/dirt problems (model CSUAS-PP).

Benefits

- Reliable, long lasting thermal actuator
- Direct replacement for manual balancing valves
- Compatible with all domestic recirculation systems
- Viega ProPress® ends save time and labor costs
- Easy install into ProPress systems
- CircuitSolver® valves are NSF/ANSI 61 Certified

Design Features

- Automatically and continuously adjusts to balance domestic hot water systems
- Viega Smart Connect® technology aids installers in identifying unpressed ends
- Never fully closes - small bypass of flow
- Every unit is tested for actuator accuracy and leak points for optimal compatibility



For more information and your local product representative, visit www.CircuitSolver.com

All CircuitSolver® Valves are
NSF/ANSI 61 Certified

 ThermOmegaTech® (877) 379-8258 | www.CircuitSolver.com

CircuitSolver® Union Assembly ProPress (CSUA-PP)

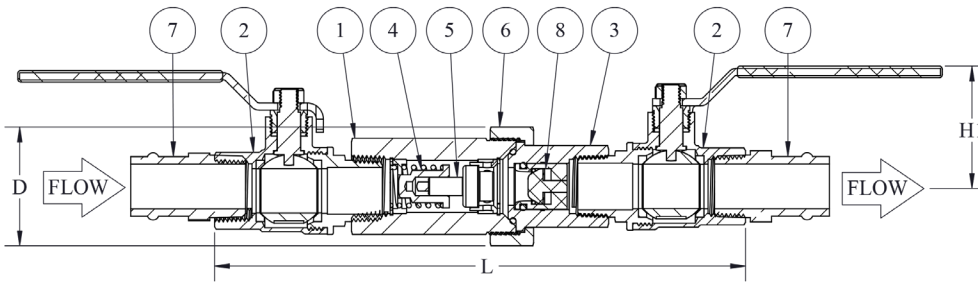

ITEM #	DESCRIPTION
1	VALVE BODY W/ UNION THREADS
2	BALL VALVE
3	INSERT - FEMALE THREADED
4	PLUG
5	THERMAL ACTUATOR
6	UNION NUT
7	ADAPTER, PROPRESS
8	CHECK VALVE (OPTIONAL)

CSU Assembly ProPress with Strainer (CSUAS-PP)

ITEM #	DESCRIPTION
1	CIRCUITSOLVER® THERMOSTATIC BALANCING VALVE WITH INTEGRATED UNION
2	NIPPLE, LEAD FREE
3	BALL VALVE, Mx F, LEAD FREE
4	STRAINER, LEAD FREE
5	ADAPTER, PROPRESS

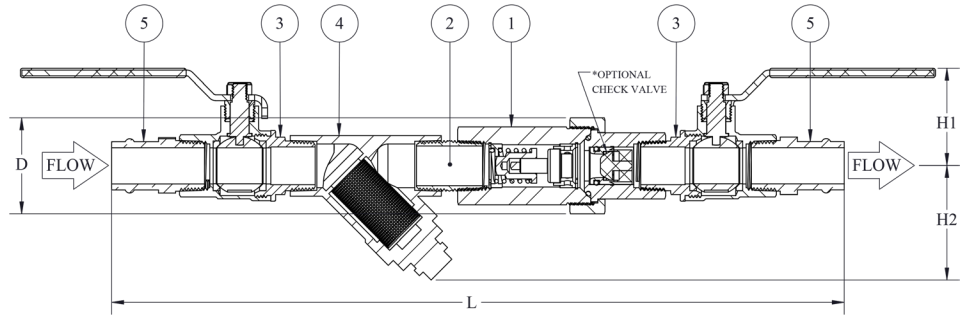

Dimensions & Capacities

Model	SIZE (NPT)	Diameter (D)		Length (L)		Height (H1)		Height (H2)		WEIGHT		C _v		MAXIMUM OPERATING PRESSURE		MAXIMUM TEMPERATURE	
		IN.	MM	IN.	MM	IN.	MM	IN.	MM	LBS.	KG	OPEN	CLOSED	PSIG	BAR	°F	°C
CSUA-PP	1/2"	1.8	46	10.1	257	1.8	46			2.3	1.0	1.3	0.1	200	14	250	121
CSUA-PP	3/4"	2.0	51	11.8	300	2.0	51			3.7	1.7	1.8	0.1				
CSUA-PP	1"	2.5	64	13.1	333	2.3	59			5.9	2.7	3.3	0.1				
CSUAS-PP	1/2"	1.8	46	13.6	345	1.8	46	2.5	64	2.8	1.3	1.3	0.1				
CSUAS-PP	3/4"	2.0	51	15.4	391	2.0	51	3.3	84	4.7	2.1	1.8	0.1				
CSUAS-PP	1"	2.5	64	18	456	2.3	59	3.8	97	7.4	3.4	3.3	0.1				

Ordering Information

CSUA-1/2-XXX-PP	1/2" CSUA-PP WITHOUT CHECK VALVE	CSUAS-1/2-XXX-PP	1/2" CSUAS-PP WITHOUT CHECK VALVE
CSUA-1/2-XXX-CV1-PP	1/2" CSUA-PP WITH CHECK VALVE (CV1)	CSUAS-1/2-XXX-CV1-PP	1/2" CSUAS-PP WITH CHECK VALVE (CV1)
CSUA-3/4-XXX-PP	3/4" CSUA-PP WITHOUT CHECK VALVE	CSUAS-3/4-XXX-PP	3/4" CSUAS-PP WITHOUT CHECK VALVE
CSUA-3/4-XXX-CV1-PP	3/4" CSUA-PP WITH CHECK VALVE (CV1)	CSUAS-3/4-XXX-CV1-PP	3/4" CSUAS-PP WITH CHECK VALVE (CV1)
CSUA-1-XXX-PP	1" CSUA-PP WITHOUT CHECK VALVE	CSUAS-1-XXX-PP	1" CSUAS-PP WITHOUT CHECK VALVE
CSUA-1-XXX-CV1-PP	1" CSUA-PP WITH CHECK VALVE (CV1)	CSUAS-1-XXX-CV1-PP	1" CSUAS-PP WITH CHECK VALVE (CV1)

Model Selection

XXX refers to the desired closing temperature. When the water temperature drops below this point the CircuitSolver® will begin to open, allowing water to easily enter the return line. For example, if you want 120°F desired return temperature and the CSUA-PP is to be installed on a 3/4" line, the model number would be CSUA-3/4-120-PP. To add optional check valve insert -CV1 directly after the temperature designation in the model number. Ex. CSUA-3/4-120-CV1-PP

Notes:

- The CircuitSolver® valve is fully open approximately 10°F below the closing temperature.
- Typical closing temperatures of the actuator include: 100°F, 105°F, 110 °F, 115°F, 120°F, 125°F, 130°F, and 140°F.
- Warranty information disclosed at www.thermomegatech.com/terms-conditions/
- ProPress® and Viega® are registered trademarks of Viega GmbH. Consult the Viega ProPress® installation manual below: www.viega.us/en/products/Catalog/Metal-systems/ProPress.html#downloads
- The Term Viega, as used in this publication, does not apply to a specific company within the various separate and distinct companies comprising the Viega group of companies. The term Viega as used in this publication refers to the Viega brand itself or generally to the Viega group of companies. References to activities in North America specifically refer to activities of Viega LLC.
- A green dot on a Viega ProPress fitting indicates the Smart Connect feature with an EPDM sealing element. For a current list of applications, please visit www.viega.us/applications.
- Zero Lead identifies Viega products meeting the lead-free requirements of NSF 61-G through testing under NSF/ANSI 372 (0.25% or less maximum weighted average lead content).