

ECONO/HAT

TEMPERATURE CONTROL VALVE

BENEFITS

- Controls fluid return temperatures - ideal for glycol tracing
- Maintains constant discharge temperatures
- Self-operating, no power or signal required
- Improves system efficiency
- Unaffected by pressure variations

DESIGN FEATURES

- Exclusive **Thermoloid**® thermal actuator
- Compact, low mass - fast response time
- Corrosion resistant - long service life
- Ram-type plug for tight, reliable shutoff
- Operates in narrow temperature band

APPLICATIONS

ECONO/HAT valves are ideal for maintaining the discharge temperature in glycol heat tracing systems. When glycol temperature exceeds the valve's set point, it will modulate closed. As heat loss occurs and glycol cools to below the set point, the valve will open to allow warmer glycol to circulate.

ECONO/HAT valves can also act as freeze protection for condensate systems. The valves open when temperatures fall to allow condensate to discharge before freezing.

In commercial aircraft, high temperature water can unexpectedly travel to the cold water lines. **ECONO/HAT** valves on cold water lines will limit flow when excessive temperatures are detected, preventing scalding of passengers and crew.

ECONO/HAT valves used on tank heating coils limit the temperatures of the heating element. By closing before coil temperatures are too high, the valves reduce the risk of over-temperature damage. When used as a sub-cooling steam trap, **ECONO/HAT** valves reduce problems associated with overheating.

When used as a sampling system safety shutoff, **ECONO/HAT** valves will remain open as long as sample temperatures are under the set point. If the sample temperature increases, the valve will shut off, protecting analyzing equipment from damage due to high temperature.

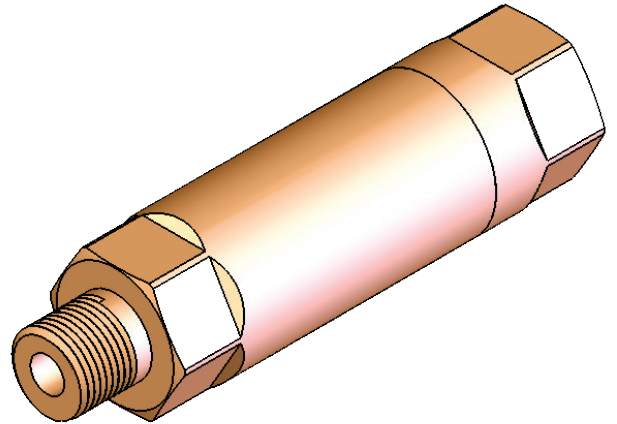

OPERATION

A thermostatic element inside the **ECONO/HAT** continuously senses the fluid temperature. If the temperature falls below the valve's set-point, the valve modulates open to allow flow.

Once the fluid temperature is back above the set-point, the valve modulates closed. This modulating action maintains a relatively constant fluid temperature even as operating conditions vary.

ECONO/HAT

TEMPERATURE CONTROL VALVE

PARTS & MATERIALS

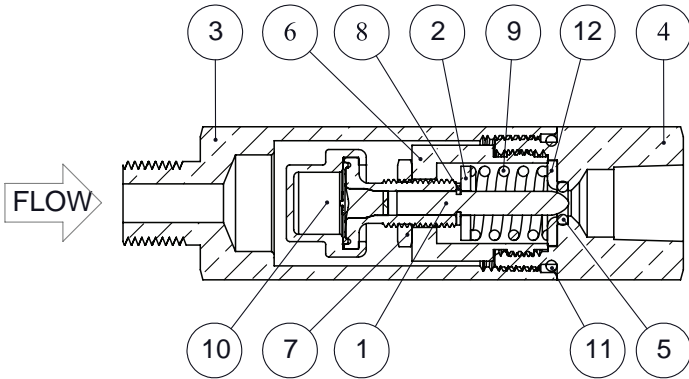

ITEM	DESCRIPTION	MATERIAL
1	RAM-TYPE PLUG	300 Series SS
2	BEARING	300 Series SS
3	VALVE BODY	Brass or 300 Series SS
4	SEAT FITTING	Brass or 300 Series SS
5	SEAT SEAL	BUNA
6	SEAT RETAINER	Brass or 300 Series SS
7	CALIBRATION LOCKNUT	300 Series SS
8	E-RING	15-7 PH SS
9	OPERATING SPRING	300 Series SS
10	THERMAL ACTUATOR	Brass or 300 Series SS
11	BODY SEAL	BUNA
12	SEAT INSERT	Brass or 300 Series SS

DIMENSIONS & CAPACITIES

SIZE (NPT)	D		L		Weight		C _v	Maximum Operat- ing Pressure	Maximum Temperature
	in	mm	in	mm	Lb	Kg			
1/4" Brass	1.0	25	3.6	89	0.4	0.2	0.5	300 PSIG (20.7 BAR)	250°F (121°C)
1/4" SS								400 PSIG (27.6 BAR)	

ORDERING

Part Number	Description
232 - 000000 - XXX	1/4" ECONO/HAT M/F
232 - 110000 - XXX	1/4" ECONO/HAT M/F SS

NOTES

1. Full open temperatures "XXX" available: 040°F, 045°F, 050°F, 060°F, 070°F, 075°F, 085°F, 095°F, 100°F, 105°F, 110°F, 115°F, 120°F, 125°F, 130°F, 140°F, 150°F, 160°F, 170°F, 175°F, 180°F, 190°F, 200°F and 210°F.
2. Note: Closing temperature is typically 10°F above opening temperature.
3. A #20 mesh strainer is recommended.
4. Warranty information disclosed at www.thermomegatech.com/terms-conditions/



ThermOmegaTech®, Inc.
353 Ivyland Road
Warminster, PA 18974

1-877-379-8258
www.ThermOmegaTech.com

ECONO/HAT
5/2/2022