

## INSTALLATION INSTRUCTIONS THERMAL DISINFECTION DUAL BALANCING VALVES WITH PROPEX FITTINGS CSUTD-D-PX

- 1) We recommend that you use a shut off valve before and after the **CircuitSolver® Thermal Disinfection Dual Valve** and a union after the valve. See schematic diagram on reverse side.
- 2) Install valve with proper flow direction as marked on valve body. This is critical with valves that have an integrated check valve.
- 3a) Use suitable pipe thread sealant rated for domestic water applications on all male pipe threads except on the stainless steel **CircuitSolver® Thermal Disinfection Dual Valve** union threads (this connection has an integrated o-ring that fully seals when hand tightened); if using PTFE sealant tape, make sure not to apply tape to the first thread to avoid cutting the PTFE tape and causing potential obstructions to flow.
- 3b) **How to apply PTFE Tape:**
  1. Clean the male and female threads of any oil or dirt.
  2. Apply tape to the male threaded end in a clockwise direction starting one thread back from the end. Hold on to one end of the tape, and wrap the threads three to six times, keeping it tight.
  3. Once the threads are completely wrapped, grab the tape with your thumb and index finger and snap it off.

**NOTE:** Upon tightening the assembly, verify that the shutoff valves are oriented so that their handles are accessible and can be operated fully without obstruction. If a reorientation after final installation is needed, loosen the **CircuitSolver® Union Nut** to rotate the section so as to not disturb the tightened components and possibly cause a leaky connection.



Scan to watch a quick tutorial video on proper reorientation instructions.

- 4) When using Uponor ProPEX® adapters, (CircuitSolver Models ending in -PX) please consult the Uponor ProPEX® Installation Manual for proper installation, tools, etc.

Visit <https://www.uponor.com/en-us/search?query=pex%20installation%20guide>

- 5) **CircuitSolver®** valves are designed to be installed at the end of each domestic hot water supply just prior to the return line. See diagram to the right.
- 6) For water systems with particulate/dirt problems, consider using a strainer if one is not already used upstream.

\*Strainer must be maintained in order to avoid flow obstruction.

### MULTI-BRANCH PARALLEL PIPING CIRCUIT:

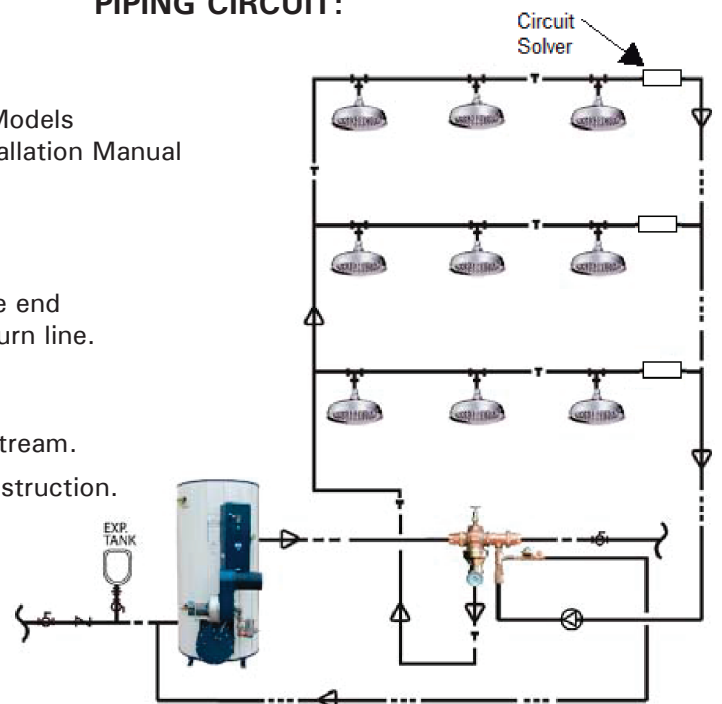

**Buy American to Build America®**

# SCHEMATIC DIAGRAMS

## CircuitSolver® Thermal Disinfection Dual Valve with ProPEX® Ends (CSUTD-D-PX)

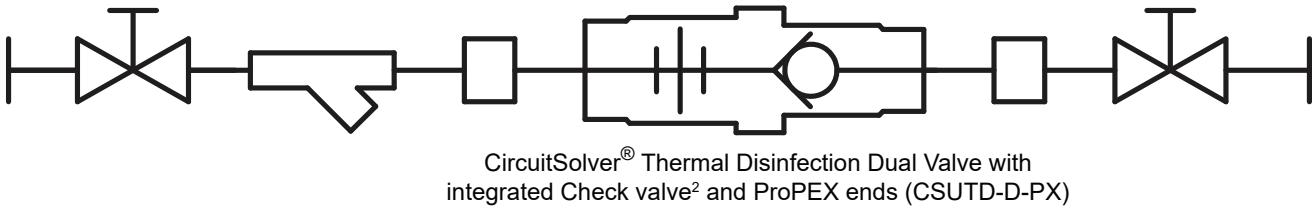
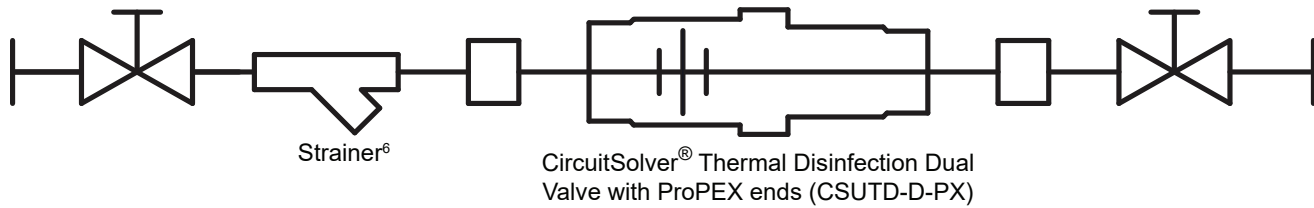
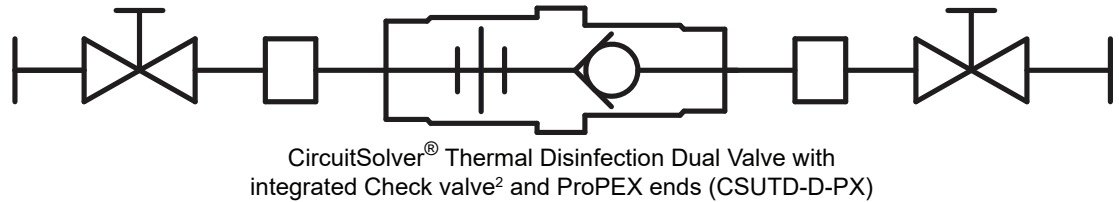
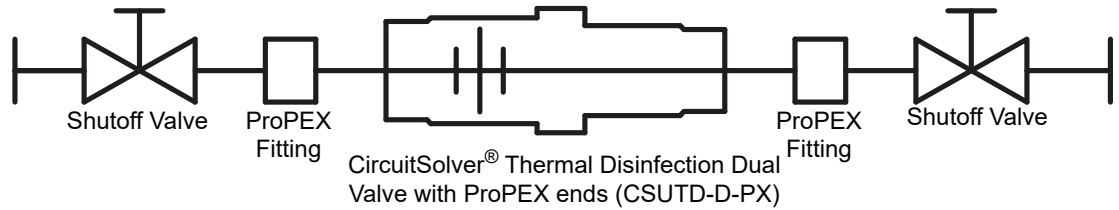

WARNING: This product can expose you to chemicals, for example lead, nickel, acrylonitrile, which are known to the State of CA to cause cancer, birth defects, or reproductive harm. For more information, go to [www.P65Warnings.ca.gov](http://www.P65Warnings.ca.gov)

Warranty information disclosed at [www.thermomegatech.com/terms-conditions/](http://www.thermomegatech.com/terms-conditions/)

ProPEX® and Uponor® are registered trademarks of Uponor

CSUTD-PX\_IM1  
REV: 11/17/22