

## GURU® DL 2.1 CH & CHS

### WATER-COOLED COMPRESSOR HEAD FREEZE PROTECTION

#### BENEFITS

- Will not trip or dump while locomotive is running
- Fully automatic - it never forgets to activate freeze protection
- Completely mechanical - No electrical or air connections
- Not affected by air flow or air temperature surrounding valve - releases only when cooling water reaches set-point
- Rapid draining
- Easy system refill
- Easy maintenance and field testability
- Slotted actuator feature prevents nuisance dumps when refilling cooling system with cold water
- Unit automatically rearms after filling and reheating
- Optional domed anti tamper cap eliminates ability to tamper with the valve resetting stem



GURU® CH



GURU® CH ANTI-TAMPER



GURU® CHS



GURU® CHS ANTI-TAMPER

#### DESIGN FEATURES

- Thermal actuator sensing surface is the only wetted part
- Easily retrofits into water-cooled air compressor heads
- Flanged and 2" NPT threaded styles
- All moving parts are stainless steel - long service life
- Design excludes cooling water chemicals and other debris from moving parts
- Paint mask minimizes accidental paint-ins
- Knob on cartridge for easy installation and removal even in awkward locations
- Choice of release temperatures: 35°F or 40°F

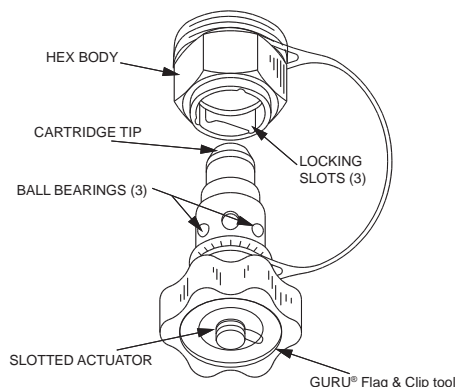

#### OPERATION

The **GURU® CH & CHS** may be thought of as an automatic freeze-out plug with one important difference: The stainless steel **GURU® Cartridge** releases itself from its body at a pre-set water temperature (35°F or 40°F), rather than being forced out by the tremendous pressure of expanding ice. This provides almost a full one inch bore to rapidly drain the typical compressor before damage can occur.

Resetting and rearming the **GURU® Plug** is easily accomplished by simply reheating the cartridge and utilizing our **GURU® Flag and Clip** tool with slotted actuator feature. This feature prevents the **GURU® Plug** from triggering open again while refilling the cooling system with cold water.

#### APPLICATIONS

Both are used for water cooled air compressor head freeze protection.

The **GURU® CHS** adapts to Gardner Denver's compressor set cooling systems. Most common on EMD's SD70 locomotives.

# GURU® DL 2.1 CH & CHS

## WATER-COOLED COMPRESSOR HEAD FREEZE PROTECTION

### GURU® DL 2.1 TYPE CHS

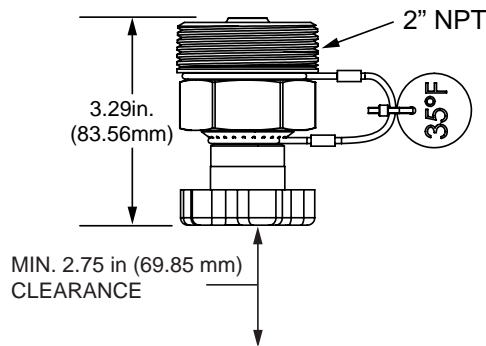

### COMPRESSOR HEAD CLEANING TOOL

- Inserts into any GURU® CH or CHS body.
- Clear compressor heads of dirt and foreign matter.
- Protects cooling jacket from blockage.
- Connects to any water source for cleaning.



### GURU® DL 2.1 TYPE CH

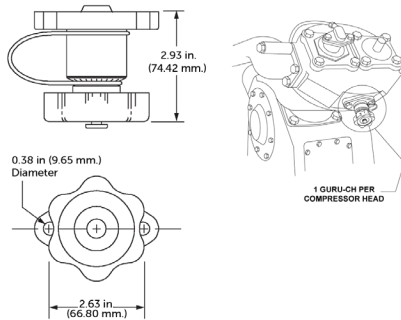

### FLAG AND CLIP (SINGLE LANYARD)



### ANTI-TAMPERING (3 LANYARDS)



- Allows refilling of locomotive with cool water without tripping of GURU® valves.
- Alerts to the presence of deactivated GURU® Plugs.
- Minimizes risks of deactivated GURU® Plug.
- Can be used with Magnum and DL 2.1 Plugs.

## ORDERING INFORMATION

PART NUMBER		DESCRIPTION	NOTES
35°	40°		
475-010110-035	NA	CARTRIDGE 35°F: ANTI- TAMPER	
475-006110-035	NA	DL2.1 TYPE-CH 35°F: ANTI- TAMPER	
475-007110-035	NA	DL2.1 TYPE-CHS 35°F: ANTI- TAMPER	
481-04-82-CART	481-04-81V-CART	DL2.1 TYPE CARTRIDGE	REPLACEMENT GURU® CH OR CHS CARTRIDGE
484-04-88	484-04-84	DL2.1 TYPE CH	
485-04-88	485-04-87	DL2.1 TYPE CHS	
04-066		ANTI-TAMPERING ASSEMBLY, WITH STROBE LIGHT	PREVENTS NUISANCE DUMPS WHEN REFILLING
04-052		FLAG AND CLIP WITH STROBE LIGHT	PREVENTS NUISANCE DUMPS WHEN REFILLING
484-04-84-CHCT		COMPRESSOR HEAD CLEANING TOOL	QUICKLY CLEANS WATER COOLED COMPRESSORS

The suitability of the valve for the intended application is the responsibility of the end user.  
GURU® CH and CHS valves are covered by a 1-year warranty.



ThermOmegaTech®, Inc.  
353 Ivyland Road  
Warminster, PA 18974

1-877-379-8258  
www.ThermOmegaTech.com

GURU DL 2.1 CH & CHS  
2/6/2024

Because of continuous improvements, ThermOmegaTech®, Inc. reserves the right to change the design and specifications without notice